

CleanaWater[®]

Dependable Odour Control
VapourGard[™]



02 4957 2886
cleanawater.com.au

CleanaWater is excited to bring the latest in odour abatement technology out of Europe and the US with our VapourGard™ range. VapourGard™ utilises the latest in odour neutralising technology without the use of water like traditional misting systems, making them ideal for large open areas and production facilities wishing to avoid bulky and expensive extraction and treatment systems.

VapourGard™ is a revolution in airborne odour control

CleanaWater's unique VapourGard™ system is more effective than fragrance and neutralising oils. That's because its active deodorisation technology destroys odour particles - rather than just masking them. The vapours stay airborne for longer than traditional sprays - allowing more effective odour treatment.

It's what makes VapourGard™ an industry-leading system. Meaning total control of airborne odours - indoors and outdoors.

More Effective Than Misting Systems	✓
Economical	✓
Low Maintenance	✓
Odour Removal	90 - 100%



Advantages of Vapour for Odour Treatment

- Deodoriser is delivered in lightweight particles, similar to the weight of the odours
- No water is needed
- Maintenance is minimal
- The deodoriser is unobtrusive
- The vaporisation system is relatively quiet, dry, and invisible
- Cost-effective to install and run
- Completely safe and environmentally friendly
- **Can be used to treat hydrogen sulphide (H₂S)**

Odours are compounds that have volatilised – transitioned to gaseous or vapour state. That is why we can smell them. We don't actually smell liquids or solids. We smell the portions of them that make the transition into the vapour state – making them light enough to travel in the air and into our nostrils.

The VapourGard™ System releases deodoriser converted to vapour form. The deodoriser vapour moves at the same speeds and in the same direction as odorous vapours. This allows the deodoriser to stay in the air for a much longer time, creating more opportunities for contact and deodorisation. The system uses a pipe to transport an air-stream filled with vaporised deodoriser around the perimeter of any area where deodorisation is desired. The type of pipe is determined by terrain and weather conditions.



VapourGard™

The vapour is created by a unique system that moves air across a tank of deodoriser. The deodoriser is designed specifically to vaporise when subjected to air movement or minor turbulence. Heat is not used. The chemical is not “evaporated” in the normal sense of the word. The vaporiser unit contains only a motor and blower, a tank, and a vacuum system for creating the vapour and delivering it into the air-stream. While some heat is created by molecular vibration at the surface of the liquid, the amount is minimal. This allows vaporisation of the deodoriser without fractionation. The composition and functionality of the deodoriser are not compromised.

The ingredients are carefully designed to vaporise together, retaining their integrity. This is why heat is not used. Heating any blend of volatile ingredients results in a loss of integrity because each component will have a different evaporation rate and temperature threshold. Using heat to create vapour simply separates the deodoriser back into its component parts.

The deodoriser was created specifically for the process of vaporisation by turbulence. It contains no propellants or alcohols, and its component parts are all approved for cosmetic use or greater by the FDA. People use most of the components of VapourGard™ deodoriser every day in their homes.

How VapourGard™ Works

We start with a cationic surfactant, blend a set of amine groups with anionic surfactants, and create sets of amino complexes with a high reactive affinity toward certain odorous groups. Many of these complexes are amino hydroxyl groups that will react in contact with organic acids, mercaptans, and other reduced sulphur compounds. With mercaptans for example the sulphur/hydrogen (SH) bond is displaced through a series of ionic reactions and replaced with the sulphur/oxygen (SO) bond of an odourless sulphate.

Some reactions involve the conversion of organic and short-chain fatty acids to esters and simple alcohols. Some complexes trap and adsorb odorous compounds, others use opposing ionic charges to combine with or displace sections of the odorous molecule. Most of the reactions are induced by ionic charge or pH differences. It is very similar to the deodorants and shampoos each of us uses daily. It simply performs in the vapour state rather than the liquid state. The system provides an environmentally and personally safe deodorisation method while conserving water and energy.



Exterior of a VapourGard™ unit



Internals of a VapourGard™ unit

Benefits to clients

CleanaWater's vapour systems are the lowest maintenance odour control products on the market. There are no nozzles to become blocked, and no portable water supply is needed. The active ingredients get to the very cause of odours, eliminating the particles. Our vapour systems are suited to large indoor and outdoor applications, especially effective on-site boundaries, aiding compliance with WHS and environmental regulations and eradicating odour complaints. The versatile design also helps you manage any site demands.

Uses and applications

- Treat a wide range of odours
- Elimination of indoor and outdoor odours
- Large factories
- Processing facilities
- On-site perimeters
- Waste Water processing and treatment facilities (H_2S)
- Solid Waste Facilities
- Recycling facilities
- Waste processing and transfer stations

VapourGard™ Construction

Our vapour systems consist of a blower, solution storage tank, piping and an electrical control box with an electronic level gauge. VapourGard™ systems are set up on the boundary of the facility, with holed tubing allowing the release of vapour into the air.

They come in a range of sizes to treat outdoor areas as large as 500 linear metres or 3000 cubic metres for indoor facilities.

Electricity requirements for the VapourGard™ 150 is a 240v 1.2amp power supply. The VapourGard™ 500 requires a 240v 32amp power supply.

Vapour formulation

The odour vaporising solution QuikAir 0900V is made up of an ester, a ketone and a cineole, with citric acid and 14 amino sucroates. This formulation has been proven to be effective on all commonly encountered types of odours. While the amino sucroates work as catalysts in the solution, the ester, ketone, acid and cineole preserve, disinfect and prevent bacterial growth in the system.

Optional accessories

Optional accessories for these vapour systems include operational triggers - including timers, atmospheric conditions and remote tank level monitoring to ensure adequate vapour solution levels.

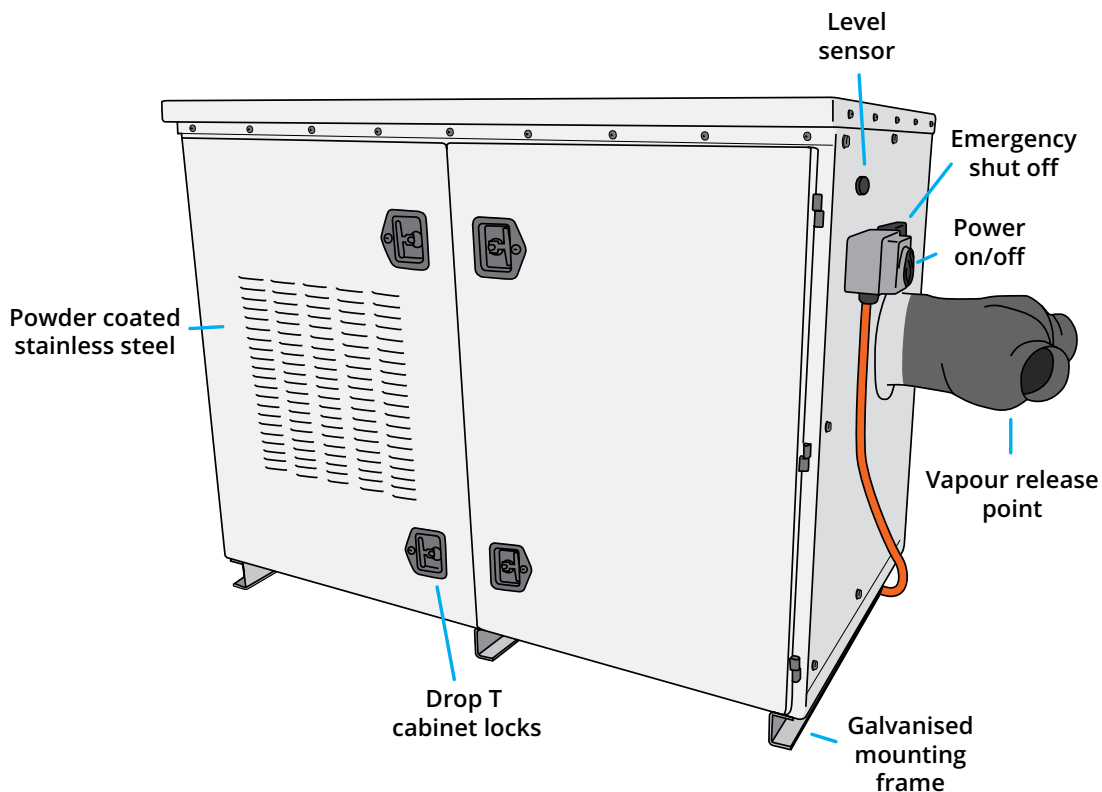

VapourGard™

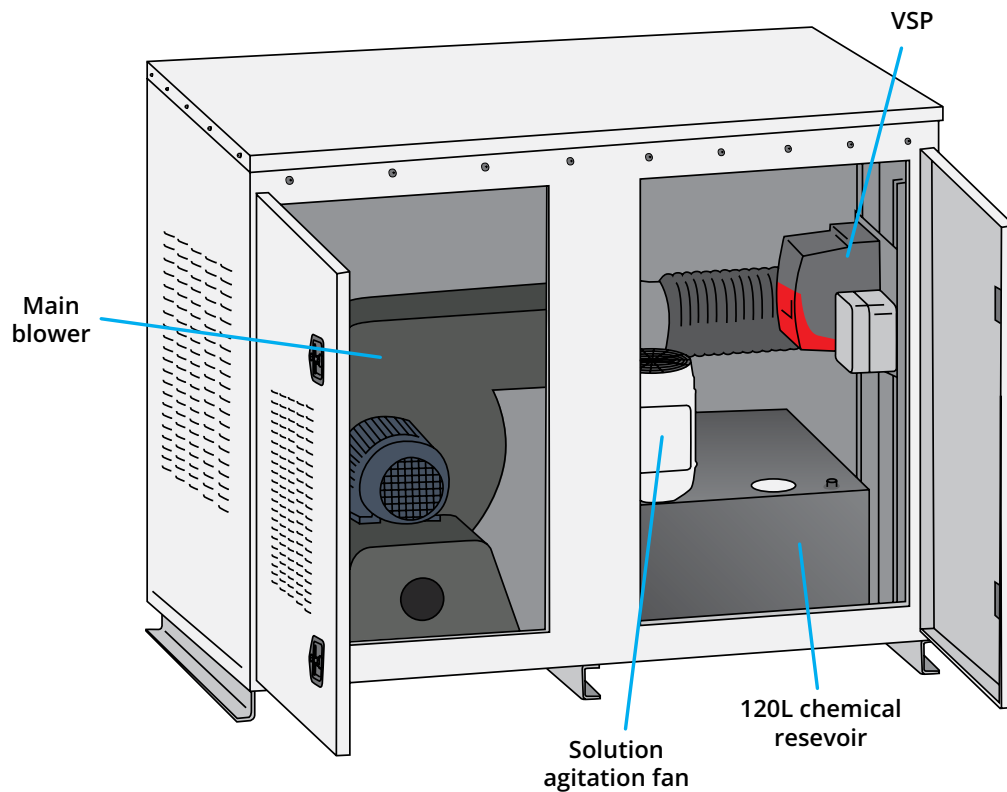

Odour Control at Lucas Heights Resource Recovery Park with VapourGard™ Technology

About Lucas Heights Resource Recovery Park

Located in Lucas Heights, Sydney, NSW, the Lucas Heights Resource Recovery Park is one of Australia's largest operating waste processing facilities, with its Renewable Energy Smart Cell® technology and additional ORRF organics facility processing over 625,000 tonnes of waste per year.

The problem

As the facility expanded and increased capacity the surrounding suburbs also became larger and the facility has begun to encroach on densely populated residential and industrial zones. By the year 2018 complaints had become a regular occurrence, and regulatory authorities had issued the site with notices requiring them to take action and reduce the amount of diffuse odours that were being released by the facility.



Our solution

Quite rapidly the situation escalated and the facility operators engaged CleanaWater's Odour Control Department to assist in coming up with a solution to ensure the facility could continue to operate while mitigating complaints from surrounding residents and businesses.

Initial enquiries from landfill management were for traditional misting systems that atomise diluted odour neutralisers into the air, although these systems can sometimes still be useful, due to the size of the operation and the importance of Select Civil, who manage the SUEZ owned facility, getting a comprehensive solution, CleanaWater recommended the facility managers take a different approach. That approach is a new technology rapidly gaining popularity in the US and Europe using vapour based neutralisers rather than atomised water-based solutions.

What we did for our client

In the summer of 2018, CleanaWater installed two VapourGard™ VG 500 systems around the boundary of the active waste cells, using our QuikAir® 0900V vapourising odour neutralising solution. Combined, the 2 systems provided the Lucas Heights facility with 1 kilometre of diffuser pipe to install between the active waste cells and the complaining constituents, which constantly releases vapourised QuikAir® 0900V into the atmosphere.

The outcome

Since installation, complaints all but ceased, and reports from operations have confirmed that odours are now minimal, noticing a substantial improvement in the air quality, even within the site premises.

The results were;

- Expert management of odour emissions
- Elimination of business and resident complaints
- Environmental regulation compliance
- Increased community approval

Why use VapourGard™

The theory behind these systems is simple: if you want to catch or treat an airborne odour, you have to use a vapour. Water-based particles are simply too heavy to stay in the air long enough and the systems that release these solutions are maintenance heavy and at times unreliable. VapourGard™ solves these issues as the vapour produced with our specialised QuikAir® V solutions, disperse at the same consistency as the surrounding air, giving the active ingredients more time and opportunity to break down the odorous air and turn them into non-volatile and non-odorous compounds.

In addition, this also led to regulatory authorities being satisfied that Select Civil had taken a very proactive and effective approach to solve their issue and operations have continued uninterrupted for the past 3 years.

CleanaWater remains committed to maintaining a cooperative relationship with Select Civil, ensuring the systems installed have all compensatory and chemical to be operational 24/7, 365 days a week. CleanaWater is also very proud of our continued involvement in the SUEZ owned Select Civil managed operation of which produces enough renewable energy to power over 47,000 homes a year.

“We have seen a fantastic improvement since the VapourGard™ system was installed 3 years ago. The system mitigates the heavy odours which are released from the site, which has improved conditions for our staff and almost completely eliminated complaints from local residents and businesses.”

GLENN CLAVERIE, LUCAS HEIGHTS LANDFILL - SITE MANAGER, SELECT CIVIL

VapourGard™

The VapourGard™ Difference

- Vapour not water based neutralisers
- No potable water supply needed for operation
- No spray meaning no airborne moisture or residue
- Vapourisation not atomisation
- Minimal Maintenance
- No blocked nozzles or nozzle replacement
- Fully automated system capabilities
- Destroys odours doesn't cover or mask them
- Suitable for large or small facilities
- Can remove airborne H₂S odours
- Economical running costs
- No more odours means no more complaints

“The VapourGard™ system is a great alternative to the other odour suppression systems out there. The unit is easy to use and maintain, does not need a portable water source to dilute the chemical and has a low chemical usage which cuts down on cost.”

NICHOLAS BHUGON, COMPLIANCE OFFICER, SITA AUSTRALIA

Basic Chemistry of QuikAir 0900V Vapourising Solutions

The product contains a blend including an ester, a ketone and cineole, as well as citric acid and 14 distinct amino sucroates (amino groups attached to a sugar/carbohydrate). It has been formulated to work in air phase on all commonly known groups of odorants.

The ester, the ketone, the acid, and the cineole are used as preservatives, disinfectants, and help to discourage the growth of bacteria in the tank. These are all FDA and EPA approved for skin contact and inhalation and are used in many medicinal and cosmetic products and applications. They have been selected to avoid the commonly used products such as alkyl ammonium chloride and other quaternary ammonium compounds typically found in deodorizers.

The amino sucroate components are all either cosmetic, food, or medicinal grade and are also approved. Each amino sucroate is chosen based on the general molecular shape, stability, and reactivity of the specific amino/carbohydrate combination. Because of their specific shapes they are able to act as catalysts in the breakdown of odorous compounds much as enzymes do, but with none of the concerns or problems associated with the use of actual enzymes found in misting technologies.



Why choose CleanaWater?

At CleanaWater, we supply odour control systems customised according to the needs of your specific site.

We uniquely offer multiple treatment options, including chemical dosing, carbon filtering, bio-filtering, and odour neutralising, to solve odour problems whether they are generated in the air, in water systems or on solid surfaces.

CleanaWater[®]

Need expert help choosing the right solution?

Call us on 02 4957 2886

Or visit cleanawater.com.au